

VASA WARRANTY CLAIM FORM

Please complete this form in its entirety and send it to us along with the part you wish to have repaired or replaced.

1. Invoice#: _____ Date of Purchase: _____

2. Model Purchased: ___ Ergometer ___ Trainer Pro SE ___ Trainer Pro ___ Trainer Sport

VASA ERGOMETER ONLY - Serial Number: _____

Located on the top of the fanwheel housing. It is visible by looking through the air inlet perforated metal screen.

3. Today's Date: _____

4. Return Authorization Number: _____

Contact Vasa, Inc. to receive this number prior to making a return.

5. Your Name: _____

6. Your Address: _____

City _____ State _____ Zip _____

7. Your daytime telephone number: (_____) _____ - _____

Your Email address: _____

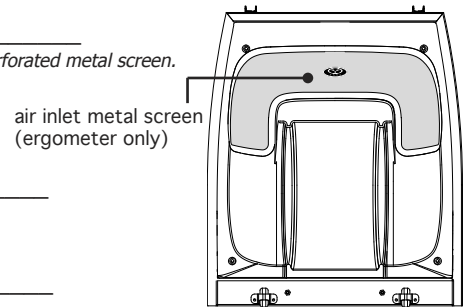

8. Please describe the problem you are having:

Part Name	Part #	Description of the Problem
_____	_____	_____
_____	_____	_____
_____	_____	_____
_____	_____	_____
_____	_____	_____

9. Please contact Vasa prior to a return numbership the defective or malfunctioning part(s) and a completed copy of this Warranty Claim form to us at:

Vasa, Inc. - Warranty Service
 1 Allen Martin Drive #5
 Essex Junction, VT 05452
 Tel: (802) 872-7101
 Fax: (802) 872-7104 or (501) 421-6254
 Email: info@vasatrainer.com
 Website: www.vasatrainer.com